



GR Series Dimensions

Styles: HMQ, HM, H

CAST IRON
GR SERIES

Style HMQ

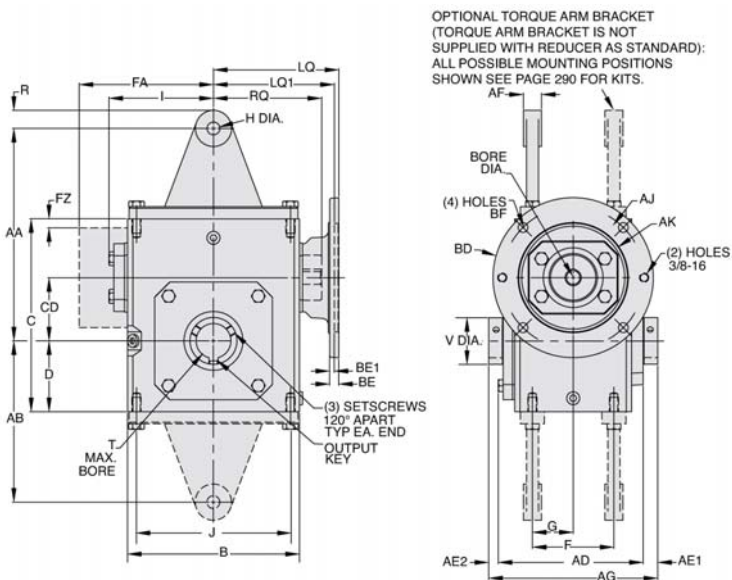

ASSEMBLIES

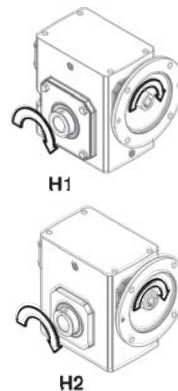

H1 SUPPLIED AS STANDARD UNLESS SPECIFIED.

Style HM

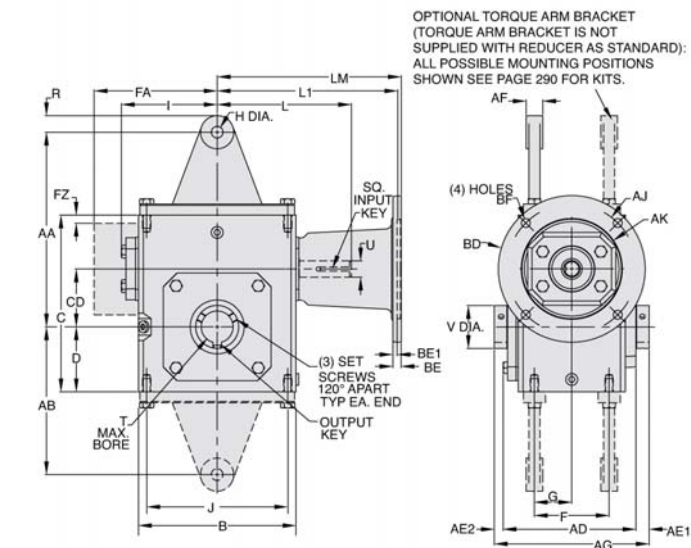

ASSEMBLIES

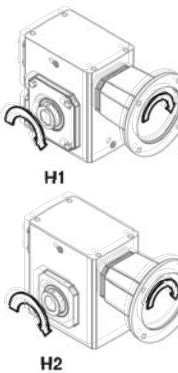

H1 SUPPLIED AS STANDARD UNLESS SPECIFIED.

Style H

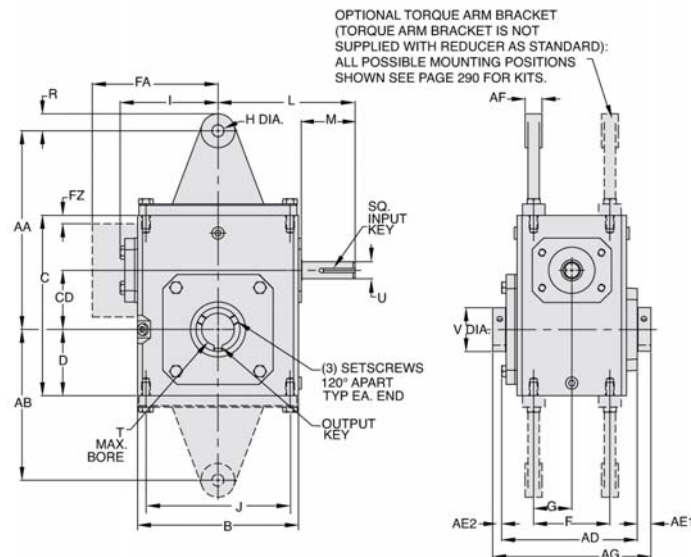

ASSEMBLIES

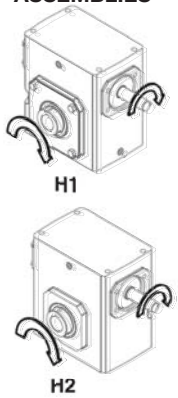

REVERSE ALL ARROWS FOR OPPOSITE INPUT SHAFT ROTATION. CONTACT FACTORY FOR OTHER MOUNTINGS OR ASSEMBLY POSITIONS.

H1 SUPPLIED AS STANDARD UNLESS SPECIFIED.

Single Reduction
Worm Gear Reducers

Double Reduction
Worm - Worm Gear Reducers

Double Reduction
Helical - Worm Gear Reducers

WASHGUARD® Reducers
and GEAR+MOTOR™

Ratio Multipliers

Accessories and
Additional Capabilities



STYLE HMQ, HM, H DIMENSIONS (Inches)

Series	AD	AE1	AE2	AG	B	C	D	CD	F	FA▼	FZ▼	G	I	J	L	M	V	T MAX -0.000 +0.0025	U +0.000 -0.0015	Input Key*	Output Key +
GR813	3.90	0.53	0.32	4.75	3.80	4.66	1.72	1.33	2.00	N/A	N/A	1.00	2.61	3.25	3.82	1.76	1.000	0.625	0.500	1/8 x 1.00	3/16 x 1.50
GR815	4.61	0.51	0.30	5.42	5.19	5.38	1.91	1.54	2.75	N/A	N/A	1.38	3.14	4.19	4.35	1.76	1.000	0.625	0.625	3/16 x 1.38	3/16 x 1.50
GR818	4.73	0.49	0.28	5.50	5.19	5.75	2.06	1.75	2.75	N/A	N/A	1.38	3.24	4.19	4.45	1.76	1.440	1.000	0.625	3/16 x 1.38	1/4 x 3.00
GR821	4.99	0.61	0.40	6.00	5.80	6.38	2.28	2.06	▲	N/A	N/A	1.44	3.61	▲	4.82	1.76	1.940	1.500	0.625	3/16 x 1.38	3/8 x 3.00
GR824	5.18	0.51	0.31	6.00	6.12	6.94	2.50	2.38	2.88	N/A	N/A	1.44	3.77	5.00	5.51	2.38	1.940	1.500	0.750	3/16 x 1.63	3/8 x 3.00
GR826x	6.01	0.60	0.39	7.00	7.38	8.00	2.94	2.63	3.38	N/A	N/A	1.69	4.34	6.38	6.07	2.38	1.940	1.500	0.750	3/16 x 1.63	3/8 x 3.00
GR830	6.53	0.60	0.36	7.50	8.12	8.88	3.25	3.00	4.00	N/A	N/A	2.00	4.84	7.00	6.57	2.38	2.756	2.188	0.875	3/16 x 1.63	1/2 x 3.00
GR832x	7.04	0.54	0.29	7.88	8.75	9.38	3.50	3.25	4.00	N/A	N/A	2.00	5.02	7.50	6.76	2.38	2.756	2.188	0.875	3/16 x 1.63	1/2 x 3.00
GR842	7.53	0.63	0.34	8.50	10.25	11.38	4.44	4.25	5.00	N/A	N/A	2.50	6.10	8.50	9.57	3.47	2.756	2.188	1.250	1/4 x 2.50	1/2 x 3.00
GR852	8.85	0.97	0.68	10.50	13.00	14.00	5.12	5.25	5.81	N/A	N/A	2.91	7.50	11.00	10.88	3.38	4.260	3.438	1.250	1/4 x3.00	7/8 x3.44
GR860	10.52	0.52	0.52	11.50	14.50	16.50	6.50	6.00	6.38	11.13	0.33	3.19	N/A	12.75	11.78	3.41	4.256	3.438	1.500	3/8 x 3.00	7/8 x 3.44
GR870	11.36	1.09	1.09	13.50	14.88	18.91	7.59	7.00	5.50	11.37	0.35	2.75	N/A	12.50	11.50	2.97	4.928	3.938	1.625	3/8 x 2.87**	1 x 1/2**
GR880	12.48	1.03	1.03	14.50	17.00	20.96	8.86	8.00	6.50	12.52	0.57	3.25	N/A	14.25	12.50	2.84	5.553	4.438	1.875	1/2 x 2.81**	1 x 1/2**
GR8100	15.78	1.39	1.39	18.50	20.88	25.47	10.36	10.00	6.88	14.69	0.51	3.44	N/A	14.75	15.50	3.76	4.256	5.438	2.250	1/2 x 3.69**	1-1/4 x 5/8**

▲ See feature comparison chart.

FEATURE COMPARISON (821)

Size	Output Shaft Diameter Needed?	Mounting Footprint Needed?	Output Key Needed?	All Other Features	Grove Gear Flexaline Interchange	LEESON IRONMAN Interchange	Replace With Series Code Below:
GR821	Identical	(F)3.00" x (J)4.75" (F)2.88" x (J)5.00"	Identical	Identical	✓	✓	GRG GRL

NOTE: If reducer is used without the accessory mounted, select based mounting dimensions on pages 52-53 (B, BM, BMQ).

**Motor Mounting Dimensions
NEMA DIMENSIONS (Inches)**

Size	48CZ LM	56C/140TC	180TC/210TC	L1 250TC	LQ 48CZ/56C/140TC	180TC	LQ1 210TC	250TC	48CZ/56C/140TC	180TC	RQ 210TC	250TC
GR813	5.63	6.07	N/A	N/A	3.46	N/A	N/A	N/A	3.09	N/A	N/A	N/A
GR815	6.16	6.60	N/A	N/A	3.99	N/A	N/A	N/A	3.62	N/A	N/A	N/A
GR818	6.26	6.70	N/A	N/A	4.09	N/A	N/A	N/A	3.59	N/A	N/A	N/A
GR821*	6.63	7.07	N/A	N/A	4.46	N/A	N/A	N/A	4.06	N/A	N/A	N/A
GR824	N/A	7.76	8.76	N/A	4.63	5.06	N/A	N/A	4.09	4.56	N/A	N/A
GR826*	N/A	8.32	9.32	N/A	5.19	5.62	N/A	N/A	4.82	5.13	N/A	N/A
GR830	N/A	8.82	9.82	N/A	5.95	6.15	6.56	N/A	5.32	5.63	6.06	N/A
GR832*	N/A	9.01	10.01	N/A	6.14	6.34	6.75	N/A	5.51	5.81	6.25	N/A
GR842	N/A	11.81	12.90	13.46	6.45	7.21	7.21	7.77	6.04	6.68	6.68	7.24
GR852	N/A	13.21	14.30	14.86	7.85	8.61	8.61	9.17	7.35	7.98	7.98	8.54
GR860	N/A	N/A	15.88	16.50	10.45	9.33	9.33	9.94	10.01	8.69	8.69	8.69
GR870	N/A	N/A	15.50	15.50	N/A	N/A	N/A	N/A	N/A	N/A	N/A	N/A
GR880	N/A	N/A	16.58	16.58	N/A	N/A	N/A	N/A	N/A	N/A	N/A	N/A

NEMA DIMENSIONS (Inches)

Frame	AJb	AK	BD	BE	BE1	Bore Dia.	Keyway♦	BFb
	3.75	3.00	4.36	0.38	N/A	.500	1/8 X 1/16	0.28
56C	5.88	4.50	6.50	0.38	N/A	.625	3/16 X 3/32	0.41
140TC	5.88	4.50	6.50	0.38	N/A	.875	3/16 X 3/32	0.41
180TC	7.25	8.50	9.00	N/A	0.50	1.125	1/4 X 1/8	0.53
210TC	7.25	8.50	9.00	N/A	0.50	1.375	5/16 X 5/32	0.53
250TC	7.25	8.50	9.00	N/A	0.50	1.625	3/8 X 3/16	0.53

IEC B5 & B3/B5 METRIC DIMENSIONS (Inches)*

Size	LQ1						RQ					
	D63D	D71D	D80D	D90D	D100LD/D112MD	D132D	D63D	D71D	D80D	D90D	D100LD/D112MD	D132D
GR813	2.62	2.65	2.89	N/A	N/A	N/A	2.45	2.47	2.71	N/A	N/A	N/A
GR815	3.15	3.18	3.42	N/A	N/A	N/A	2.98	3.00	3.24	N/A	N/A	N/A
GR818	3.25	3.28	3.52	N/A	N/A	N/A	2.95	2.97	3.21	N/A	N/A	N/A
GR821*	3.62	3.65	3.89	N/A	N/A	N/A	3.43	3.44	3.68	N/A	N/A	N/A
GR824	N/A	3.72	4.34	N/A	N/A	N/A	3.46	3.71	N/A	N/A	N/A	N/A
GR826*	N/A	4.28	4.90	4.90	5.30	N/A	N/A	4.09	4.72	4.72	5.07	N/A
GR830	N/A	4.78	5.41	5.41	5.88	N/A	N/A	4.59	5.22	5.22	5.57	N/A
GR832*	N/A	4.97	5.59	5.59	6.07	N/A	N/A	4.78	5.41	5.41	5.76	N/A
GR842	N/A	N/A	N/A	6.38	6.39	7.17	N/A	N/A	N/A	6.16	6.14	6.93
GR852	N/A	N/A	N/A	7.78	7.78	8.57	N/A	N/A	N/A	7.46	7.45	8.24

IEC B5 & B3/B5 METRIC DIMENSIONS (MM)

Frame	AJ	AK	BD	BE	Bore Dia.	Keyway♦	BF TAP	OD
D63D	115	95	117	10	11	4 X 2	M8 X 1.25	131
D71D	130	110	132	11	14	5 X 2.5	M8 X 1.25	146
D80D	165	130	165	15	19	6 X 3	M10 X 1.50	184
D90D	165	130	165	15	24	8 X 3.5	M10 X 1.50	184
D100LD/D112MD	215	180	216	18	28	8 X 3.5	M12 X 1.75	237
D132D	265	230	267	18	38	10 X 4	M12 X 1.75	290

* Max bore dimensions shown. For additional bores available, refer to page 20.

* Applies to double output shaft

** Key not provided with gear reducer. Keyway dimension shown.

♦ Keyway width by depth

⊙ Mounting holes rotated 45 degrees from positions shown on Size GR860, Style HM with frame sizes 180TC-250TC.

■ 48CZ not available

● 180TC not available

⊕ Metric IEC B5 input flange options are available only on quill input styles.

* Dimensions same for GRG and GRL Series

* Style H and HM only.

▼ Sizes 860-8100 are supplied with a fan. Dimensions refer to fan guard location.

Note: Torque arm bracket available separately. Refer to page 274 for kits. If a special bracket is required, refer to Style BMQ dimensions for mounting pad dimensions on top/bottom of reducer.



For safety, purchaser or user should provide protective guards over shaft extensions and any couplings, sheaves and belts, sprockets and chains, etc., mounted thereon.

Single Reduction
Worm Gear Reducers

Double Reduction
Worm - Worm Gear Reducers

Double Reduction
Helical - Worm Gear Reducers

WASHGARD® Reducers
and GEAR-HMOTOR™

Ratio Multipliers

Accessories and
Additional Capabilities

WASHGUARD® Maximum Rating Tables



Size 824 • GR, EL Series

Style WBMQ

Style WHMQ



824 Series

Ratio	Input RPM	Output RPM†	Input HP	Output HP	Output Torque (lb-in)	NEMA C Input Frame▲	Left Hand Catalog No.	Right Hand Catalog No.	Double Extension Catalog No.	Hollow Output Catalog No.*
5	1750	350.0	5.323	4.985	898	143-5TC	<u>8243037</u>	<u>8243049</u>	<u>8243061</u>	<u>8243513.XX</u>
7.5	1750	233.3	3.992	3.685	995	143-5TC	<u>8243038</u>	<u>8243050</u>	<u>8243062</u>	<u>8243514.XX</u>
10	1750	175.0	3.564	3.253	1172	143-5TC	<u>8243039</u>	<u>8243051</u>	<u>8243063</u>	<u>8243515.XX</u>
15	1750	116.7	2.765	2.439	1318	56C	<u>8243004</u>	<u>8243016</u>	<u>8243028</u>	<u>8243504.XX</u>
						143-5TC	<u>8243040</u>	<u>8243052</u>	<u>8243064</u>	<u>8243516.XX</u>
20	1750	87.5	2.326	1.972	1421	56C	<u>8243005</u>	<u>8243017</u>	<u>8243029</u>	<u>8243505.XX</u>
						143-5TC	<u>8243041</u>	<u>8243053</u>	<u>8243065</u>	<u>8243517.XX</u>
25	1750	70.0	1.967	1.615	1454	56C	<u>8243006</u>	<u>8243018</u>	<u>8243030</u>	<u>8243506.XX</u>
						143-5TC	<u>8243042</u>	<u>8243054</u>	<u>8243066</u>	<u>8243518.XX</u>
30	1750	58.3	1.653	1.317	1423	56C	<u>8243007</u>	<u>8243019</u>	<u>8243031</u>	<u>8243507.XX</u>
						143-5TC	<u>8243043</u>	<u>8243055</u>	<u>8243067</u>	<u>8243519.XX</u>
40	1750	43.8	1.342	0.994	1433	56C	<u>8243008</u>	<u>8243020</u>	<u>8243032</u>	<u>8243508.XX</u>
						143-5TC	<u>8243044</u>	<u>8243056</u>	<u>8243068</u>	<u>8243520.XX</u>
50	1750	35.0	1.137	0.795	1432	56C	<u>8243009</u>	<u>8243021</u>	<u>8243033</u>	<u>8243509.XX</u>
						143-5TC	<u>8243045</u>	<u>8243057</u>	<u>8243069</u>	<u>8243521.XX</u>
60	1750	29.2	0.967	0.656	1418	56C	<u>8243010</u>	<u>8243022</u>	<u>8243034</u>	<u>8243510.XX</u>
80	1750	21.9	0.455	0.288	830	56C	<u>8243011</u>	<u>8243023</u>	<u>8243035</u>	<u>8243511.XX</u>
100	1750	17.5	0.307	0.180	648	56C	<u>8243012</u>	<u>8243024</u>	<u>8243036</u>	<u>8243512.XX</u>

For input/ output shaft overhung load and thrust load ratings, refer to pages 419-422.

▲ Contact Factory for other motor flanges available.

† For gear reducer ratings at other input speeds, refer to basic reducer selection tables on pages 30-31.

How To Build a Part Number For Size GR824, EL824

1. Select partial catalog number from the selection table
2. Replace leading “_” with series code (GR, EL)
3. For Hollow output, replace “XX” suffix with bore code.

Example:

GR Series Style WBMQ, 10:1 Left Hand Output, 140TC
GR-WBMQ824-10-L-140, GR8243039

Available bore codes

Fraction Size	1"	1-1/8"	1-3/16"	1-1/4"	1-7/16"	1-1/2"
Decimal Size	1.000	1.125	1.188	1.250	1.438	1.500
Output Bore Code	16	18	19	20	23	24

* Catalog numbers are for hollow output shaft reducers.

When ordering, substitute the XX suffix with the required output bore code.